

ITEM NO.	QTY.	DESCRIPTION	LENGTH
1	1	89x89x3.50 RHS	1450
2	1	Stop flange	
3	2	M12 Nut	

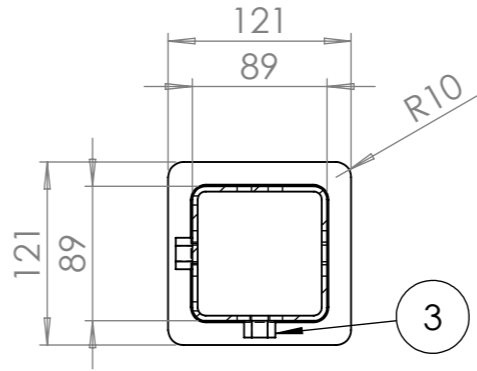

SECTION A-A
SCALE 1 : 5

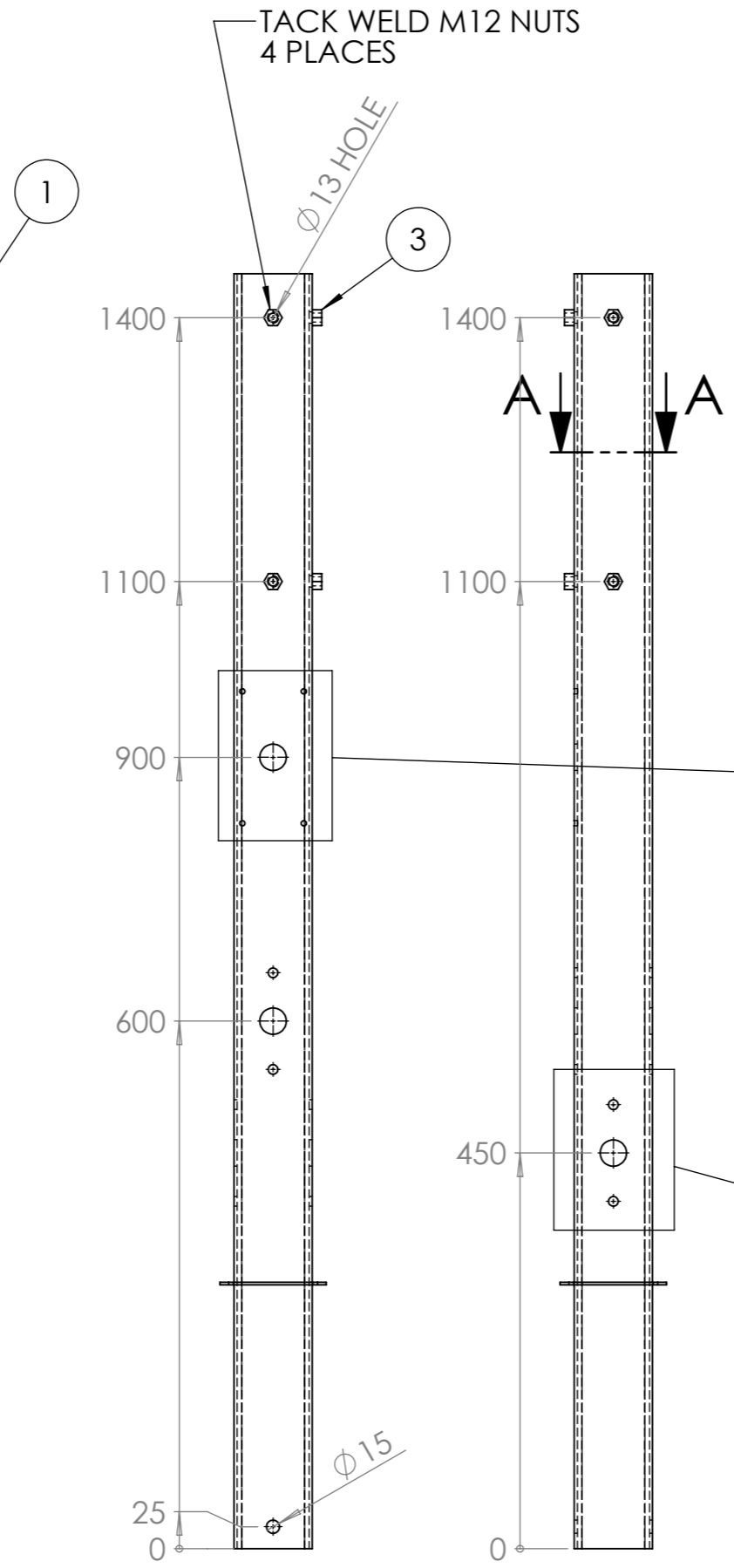
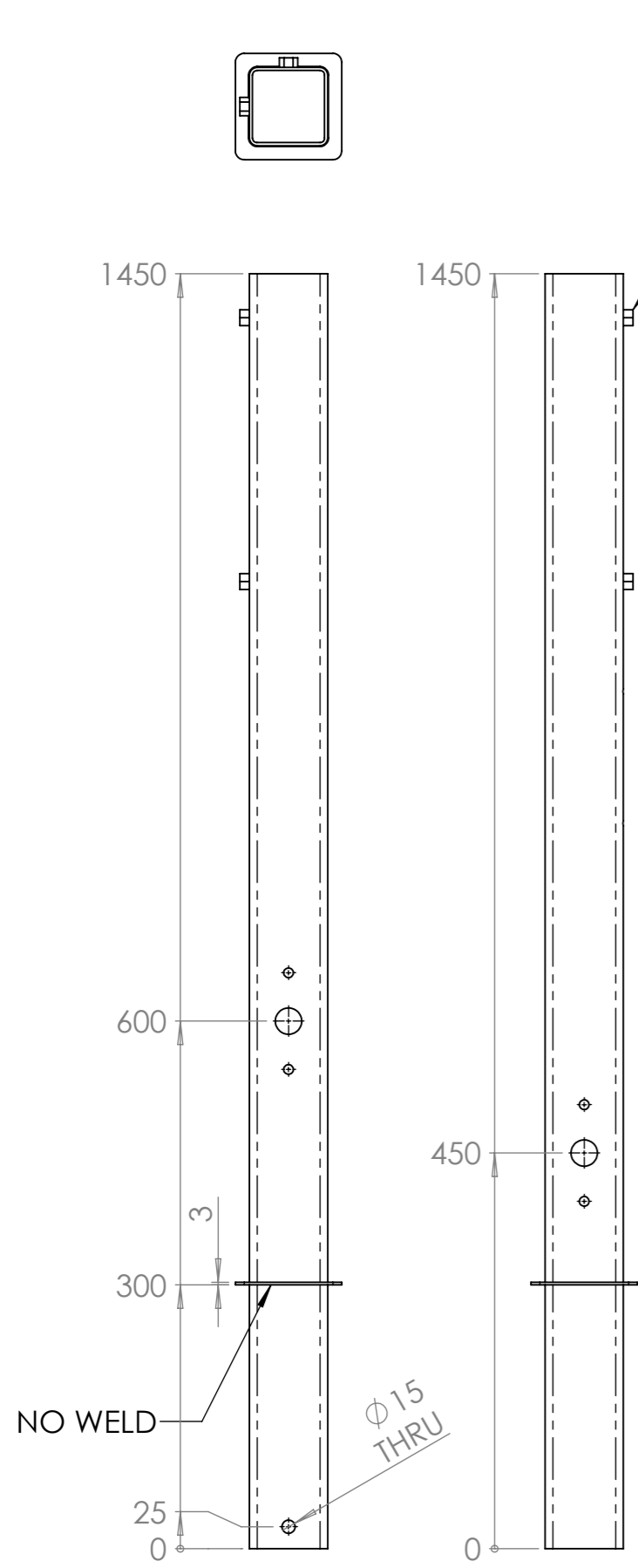
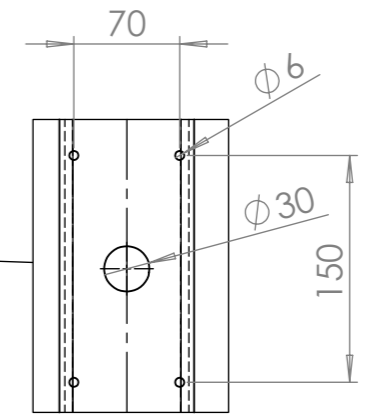

DETAIL C
SCALE 1 : 5

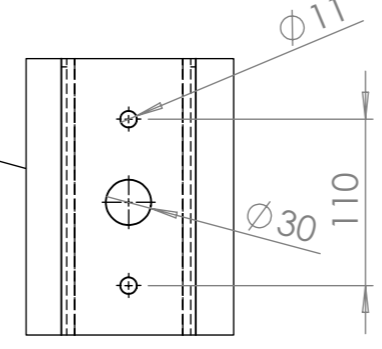

DETAIL B
SCALE 1 : 5
4 PLACES

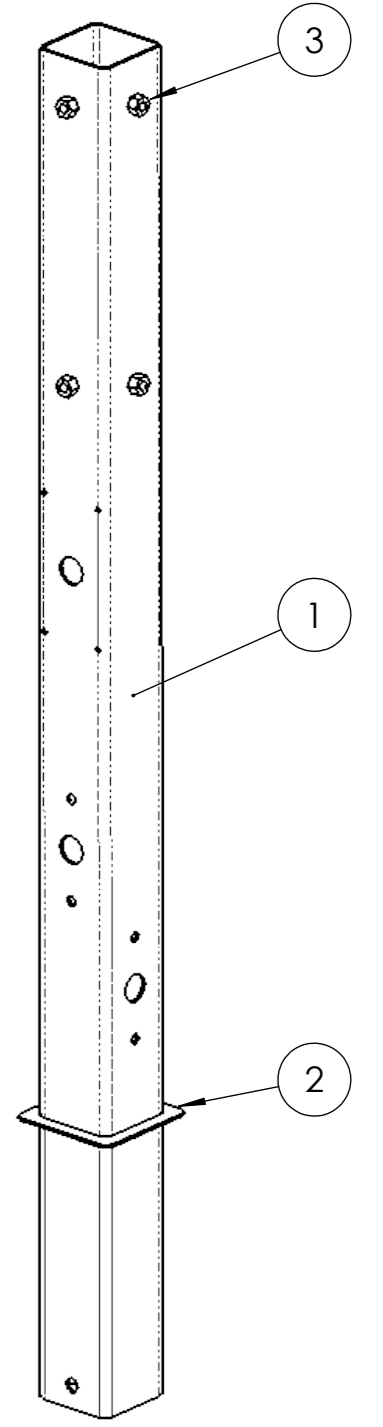

JUNO ENGINEERING LTD
9 GARLAND ST
Matamata, New Zealand 3440
PHONE 07 888 8635

Copyright in this drawing resides in:
JUNO ENGINEERING LTD
All drawings remain the property of Juno Engineering Ltd, they may not be copied or reproduced without permission of the company.

PROJECT
SHEET DESCRIPTION
DRAWN BY CRP DRAWN 15/09/2022 APPROX. WEIGHT 13134.45

DESCRIPTION
022147-30-01 Pole extension
DWG No.
SURFACE AREA SHEET 1 / 1 SIZ A3 MR