

ITEM NO.	SW-File Name(File Name)	DESCRIPTION	QTY.
1	022147-50-01 E box		1
2	022147-50-02 E box lid		1
3	022147-9 COMAC 01988- Key Locking Cam Lock		1

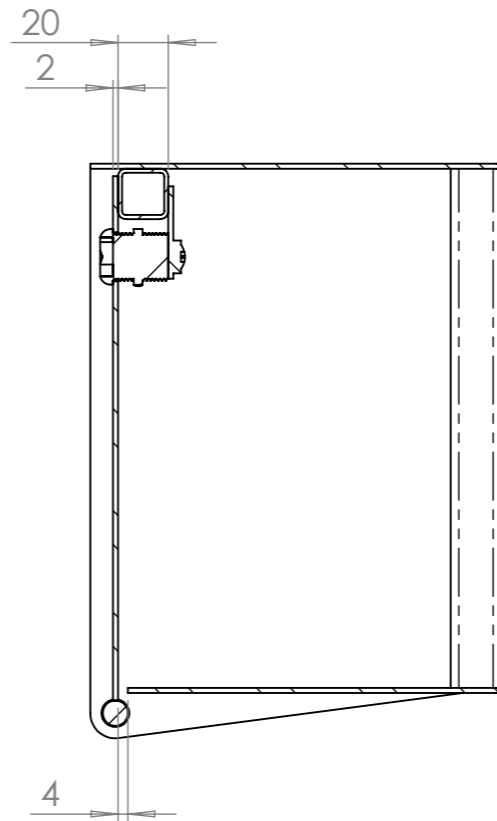

SECTION A-A

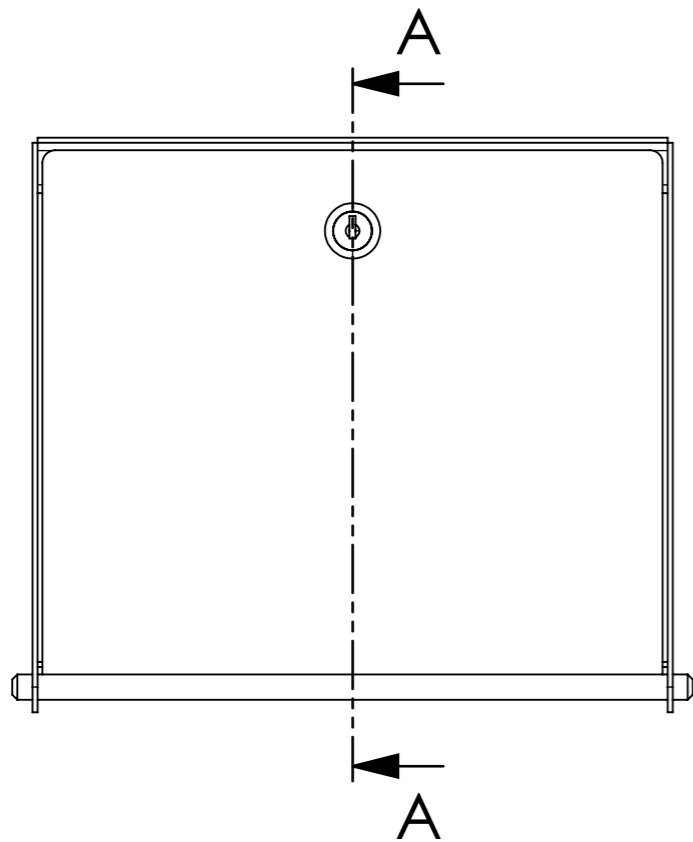
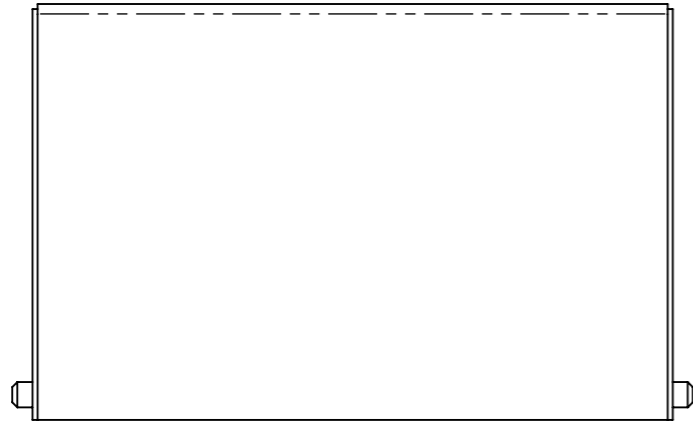
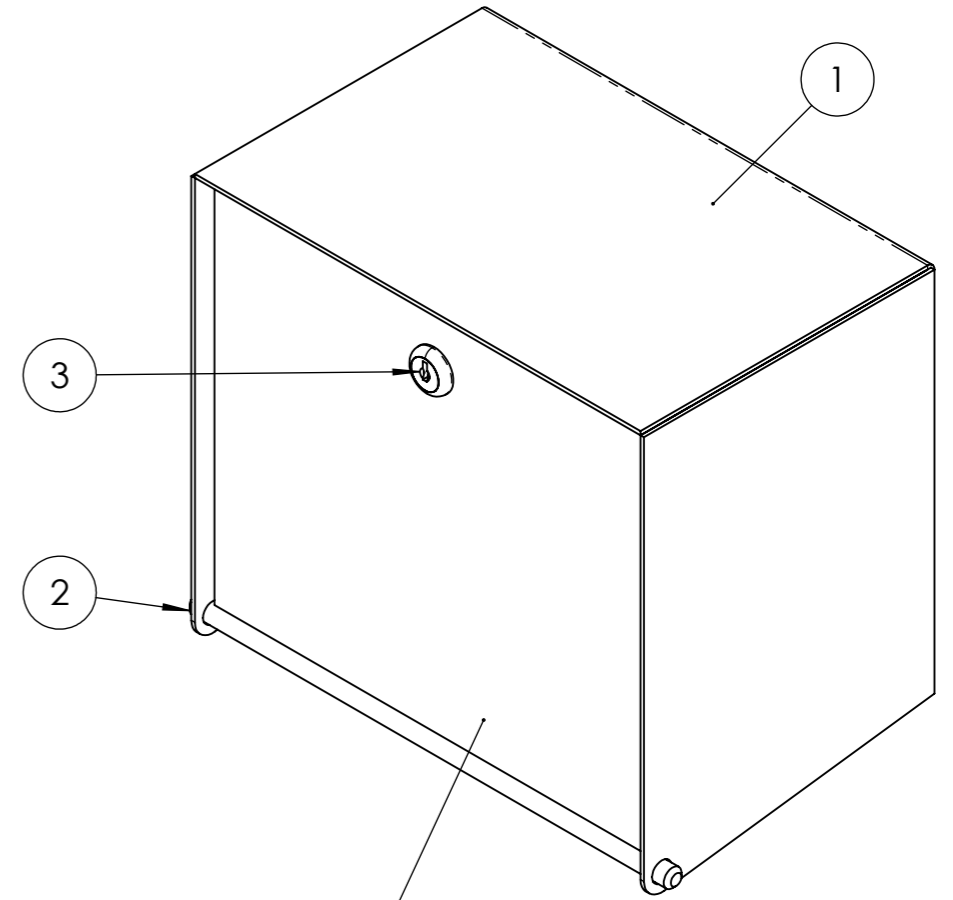

NOTE: ASSEMBLE DOOR PRIOR TO MANUFACTURE OF BOX (2)



JUNO ENGINEERING LTD
9 GARLAND ST
Matamata, New Zealand 3440
PHONE 07 888 8635

Copyright in this drawing resides in:
JUNO ENGINEERING LTD

ALL DIMENSIONS IN mm
DO NOT SCALE
DEBUR SHARP EDGES
IF IN DOUBT ASK



All drawings remain the property of Juno Engineering Ltd, they may not be copied or reproduced without permission of the company.

PROJECT

SHEET DESCRIPTION

XX

DRAWN BY

CRP

DRAWN

14/09/2022

APPROX. WEIGHT

DESCRIPTION

022147-50 E Box

DWG No.

SURFACE AREA

SHEET 1 / 1

SIZ A3

MR AN